

FOOTSTOOLS



PRATIKO



COMPLIANT
EUROPEAN
EN 14183



Footstool:

Professional footstool: with a structure made entirely of aluminium and wide non-slip steps, 200 mm deep.

Ideal for storage in confined spaces because, thanks to its retractable steps, it occupies only 8 cm.

Features:

- Rectangular side rails, 70X25 and 35X20 mm
- 200 mm non-slip flat steps
- 250 mm spacing
- Non-slip caps at side rail ends
- Sliding wheel kit at the base for handling (on request)
- Load bearing capacity 150 kg
- **European Standard EN 14183**



• Closed PratiKO

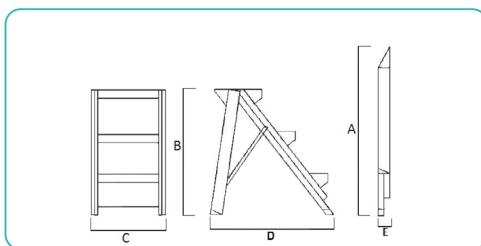

	CODE	A(m)	B(m)	C(m)	D(m)	E(m)	N. Gr.	Kg	PRICES
Without guardrail	A16SCSP2	0,80	0,50	0,53	0,50	0,075	2	4,50	€ 131,00
	A16SCSP3	1,10	0,75	0,55	0,75	0,075	3	6,00	€ 179,50
	A16SCSP4	1,40	1,00	0,57	1,00	0,075	4	7,50	€ 243,50

**PRATIKO
WITH GUARDRAIL**

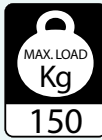

COMPLIANT
EUROPEAN
EN 14183



- Folding guardrail
- Height 50 cm



- Sliding wheel kit at the base for handling
- CODE: KITRUO
- ✓ Price: € 29.50

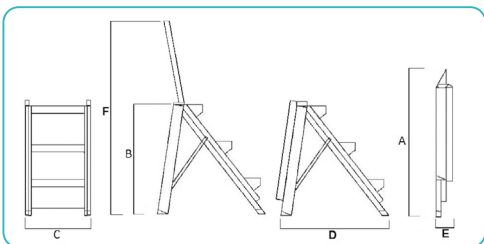

	CODE	A(m)	B(m)	C(m)	D(m)	E(m)	F(m)	N. Gr.	Kg	PRICES
With guardrail	A16SCSPI2	0,80	0,49	0,53	0,50	0,14	1,14	2	5,50	€ 233,00
	A16SCSPI3	1,10	0,74	0,55	0,75	0,14	1,39	3	7,00	€ 281,50
	A16SCSPI4	1,40	0,99	0,57	1,00	0,14	1,64	4	8,50	€ 344,50

PLANK



COMPLIANT
WITH LEG. DECREE
81/2008 Art. 113

COMPLIANT
EUROPEAN
UNI EN 14122



PLANK ladder

Work Platform perfect for continuous work at low heights thanks to the length of its platform of various sizes. Ideal for car body mechanics, painters, masons and gardeners

Features:

- Side rail: 67x25 mm
- Flat steps: 80 mm
- The side ladders can be folded for easy transport.
- The ladder has hooks to prevent folding during use
- The platform has telescopic stabilisers for more stability
- Load bearing capacity 150 kg

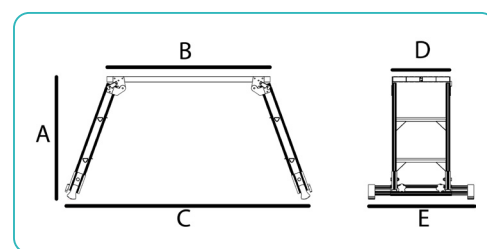

CODE	A(m)	B(m)	C(m)	D(m)	E(m)	N.Gr*	Kg	Price each
PLANK1050	0,50	1,00	1,30	0,35	min 0,45 - max 0,64	2	9,60	€ 511,50
PLANK1075	0,75	1,00	1,49	0,35	min 0,45 - max 0,64	3	10,80	€ 528,00
PLANK1100	1,00	1,25	2,00	0,35	min 0,45 - max 0,64	4	12,00	€ 555,00

CODE	A(m)	B(m)	C(m)	D(m)	E(m)	N.Gr*	Kg	Price each
PLANK15050	0,50	1,50	1,80	0,35	min 0,45 - max 0,64	2	11,60	€ 577,50
PLANK15075	0,75	1,50	1,99	0,35	min 0,45 - max 0,64	3	12,80	€ 610,50

CODE	A(m)	B(m)	C(m)	D(m)	E(m)	N.Gr*	Kg	Price each
PLANK2050	0,50	2,00	2,30	0,35	min 0,45 - max 0,64	2	13,60	€ 687,50
PLANK2075	0,75	2,00	2,49	0,35	min 0,45 - max 0,64	3	14,80	€ 720,50
PLANK2100	1,00	2,00	2,67	0,35	min 0,45 - max 0,64	4	16,00	€ 759,00

The number of steps includes the platform



- Optional handrail
- CODE: A50CORR167
- ✓ Price each € 80.50



- Safety hook



- Optional retractable and turning castors
- CODE: RUOPLANK
- ✓ Price € 176.00 per pair

STABILIA STABILIA PLUS WITH GUARDRAIL



- **Stabilia**
- Complete with 4 wheels for handling
- **European Standard EN 14183**

- **Stabilia Plus**
- Lever system for handling and locking with adjustable stiffener at the rear
- Can be with front exit
- **European Standard EN 131.7**

Footstool:

Ideal for industrial use, made of aluminium and provided with guardrail.

Features:

- 90x25 mm rectangular side rails
- 200 mm non-slip flat steps
- 250 mm spacing
- Inclination at 60°
- Extensive platform:
 - 600x600 for Stabilia
 - 600x800 for Stabilia Plus
- External width
 - Stabilia: 600 mm
 - Stabilia Plus: 650 mm
- 4 articulated shoes at the base
- With wheels
- **Compliant with Leg. Decree 81/2008**

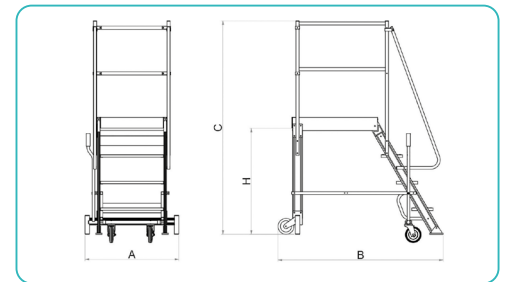
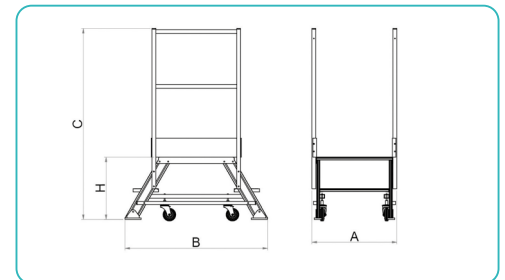

STABILIA mm 600X600							
CODE	H(m)	A(m)	B(m)	C(m)	N. Gr. *	Kg	PRICES
STABILIA2	0,49	0,67	1,13	1,50	2	25	€ 850,50
STABILIA3	0,75	0,67	1,42	1,76	3	29	€ 937,50
STABILIA4	0,99	0,67	1,71	2,05	4	33	€ 1.025,00

STABILIA PLUS mm 600X800							
CODE	H(m)	A(m)	B(m)	C(m)	N. Gr. *	Kg	PRICES
STABILIAPLUS3	0,75	0,72	1,42	1,76	3	31	€ 1.056,00
STABILIAPLUS4	1,00	0,72	1,55	2,01	4	34	€ 1.098,00
STABILIAPLUS5	1,25	0,72	1,69	2,26	5	38	€ 1.149,50
STABILIAPLUS6	1,50	0,72	1,84	2,51	6	41	€ 1.204,50
STABILIAPLUS7	1,75	0,72	1,98	2,76	7	44	€ 1.265,00
STABILIAPLUS8	2,00	0,72	2,14	3,01	8	50	€ 1.331,00

*The number of steps includes the platform

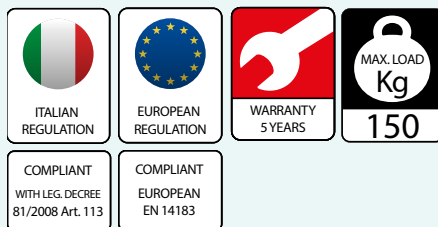

Footstool:

Professional footstool with side rails in insulated fibreglass
 It is suitable where the voltage is less than 1000 V AC and 1500 V DC, as per standard

Features:

- 75x20 mm rectangular side rails (rear) and 100x20 (front)
- 200 mm non-slip flat steps
- 250 mm spacing
- Non-slip caps at side rail ends
- Load bearing capacity 150 kg
- **Dielectric certification for fibre-glass**
- **European Standard EN 14183**

€



- **Sliding wheel kit at the base for handling**
- **CODE: KITRUO**
- ✓ **Price: € 29.50**

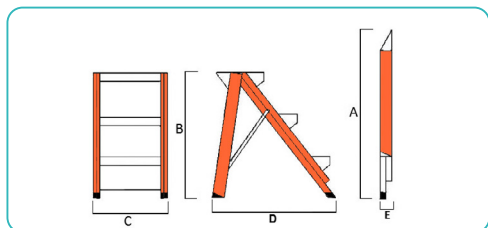
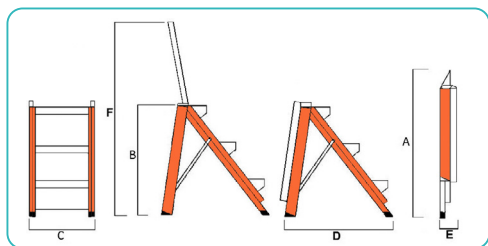

	CODE	A(m)	B(m)	C(m)	D(m)	E(m)	F(m)	N. Gr.	Kg	PRICES
With guardrail	IPA16SCSPI2	0,83	0,52	0,55	0,53	0,15	1,07	2	6,5	€ 368,50
	IPA16SCSPI3	1,15	0,75	0,58	0,75	0,16	1,30	3	8,5	€ 489,50
	IPA16SCSPI4	1,47	1,00	0,61	1,00	0,17	1,59	4	11,00	€ 599,50

	CODE	A(m)	B(m)	C(m)	D(m)	E(m)	N. Gr.	Kg	PRICES
Without guardrail	IPA16SCSP2	0,83	0,52	0,55	0,53	0,12	2	5,50	€ 264,00
	IPA16SCSP3	1,15	0,75	0,58	0,75	0,12	3	7,50	€ 385,00
	IPA16SCSP4	1,47	1,00	0,61	1,00	0,13	4	10,00	€ 495,00

FLAVIA



COMPLIANT
EUROPEAN
EN 14183

COMPLIANT
WITH LEG. DECREE
81/2008 Art. 113



Folding footstool:

Folding footstool with a frame made entirely of aluminium, with large 200 mm non-slip steps and guardrail.

Features:

- 84x25 mm rectangular side rails
- 200 mm non-slip flat steps
- Platform floor of 400 mm
- Folding guardrail
- 2 shoes at the front
- 2 non-slip caps at the rear part
- Load bearing capacity 150 kg
- **European Standard 14183**

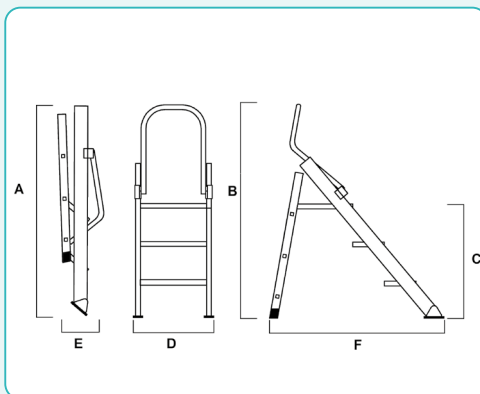

• Flavia closed

CPDE	A(m)	B(m)	C(m)	D(m)	E(m)	F(m)	Kg	N.Gr.*	M ³	PRICES
A16FLA2	0,97	1,13	0,49	0,49	0,28	0,88	8,50	2	0,13	€ 503,50
A16FLA3	1,32	1,38	0,74	0,49	0,28	1,15	10,50	3	0,18	€ 551,00
A16FLA4	1,70	1,62	0,98	0,49	0,28	1,36	12,50	4	0,23	€ 613,50

*The number of steps includes the platform



DOMINO

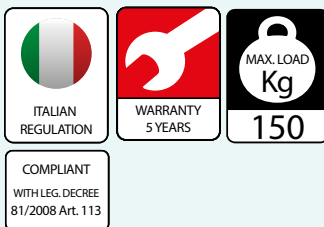

Footstool:

Professional footstool, fixed, with square 25x25 mm aluminium tube structure, wide non-slip steps, 200 mm deep, 2 x 125mm wheels at the rear for easy handling.

- Load bearing capacity 150 kg
- **Compliant with Leg. Decree 81/2008**

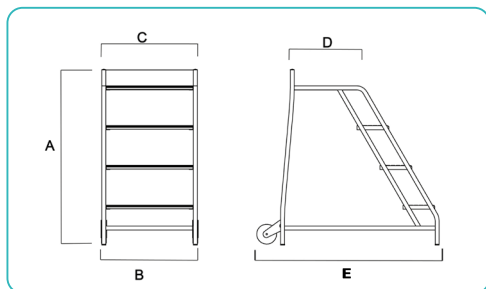

CODE	A(m)	B(m)	C(m)	D(m)	E(m)	N. Gr.*	Kg	PRICES
A16SCSA3Q	0,75	0,62	0,60	0,40	0,98	3	11,00	€ 551,00
A16SCSA4Q	1,00	0,62	0,60	0,40	1,04	4	13,00	€ 583,00

*The number of steps includes the platform

Footstool:

Sturdy footstool made entirely of aluminium, 25x25x2 mm aluminium tube frame, 200 mm aluminium steps. Guardrail/handrail on request

- Load bearing capacity 150 kg
- **Compliant with Leg. Decree 81/2008**

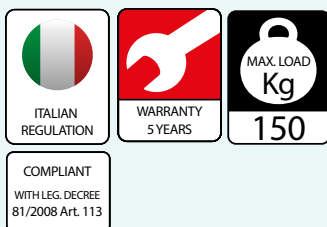
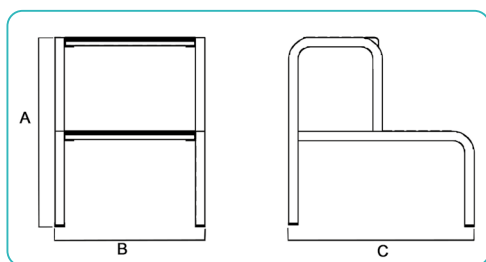

STEP



CODE	A(m)	B(m)	C(m)	N. Gr.	Kg	PRICES
A16STEP1	0,25	0,40	0,25	1	1,70	€ 102,00
A16STEP2	0,50	0,40	0,48	2	3,20	€ 160,50
A16STEP3	0,75	0,40	0,73	3	4,70	€ 225,50

TANGO

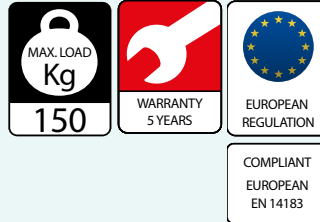

Footstool:

Ideal for industrial use, made of aluminium and it can be provided with a guardrail.

Features:

- 90x25 mm rectangular side rails
- 200 mm non-slip flat steps
- 250 mm spacing
- Inclination at 45° / 60°
- Large platform, 600x600 / 800x800 mm
- External width: 600 and 800 mm
- 4 articulated shoes at the base
- Load bearing capacity 150 kg
- It allows inserting a guardrail
- **European Standard EN 14183**

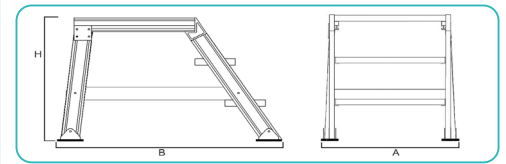

TANGO 60° mm 600x600

CODE	H(m)	A(m)	B(m)	N. Gr. *	Kg	PRICES
A16TA60602	0,50	0,68	0,94	2	12,00	€ 610,00
A16TA60603	0,75	0,68	1,11	3	15,00	€ 697,50
A16TA60604	1,00	0,70	1,27	4	18,00	€ 784,50

TANGO 45° mm 600x600

CODE	H(m)	A(m)	B(m)	N. Gr. *	Kg	PRICES
A16TA45603	0,60	0,67	1,26	3	14,00	€ 770,00
A16TA45604	0,80	0,68	1,49	4	16,00	€ 857,00
A16TA45605	1,00	0,70	1,70	5	18,00	€ 959,00

TANGO 60° mm 800x800

CODE	H(m)	A(m)	B(m)	N. Gr. *	Kg	PRICES
A16TA60802	0,50	0,85	1,14	2	18,00	€ 732,50
A16TA60803	0,75	0,87	1,31	3	21,00	€ 837,50
A16TA60804	1,00	0,90	1,47	4	24,00	€ 942,00

TANGO 45° mm 800x800

CODE	H(m)	A(m)	B(m)	N. Gr. *	Kg	PRICES
A16TA45803	0,60	0,85	1,46	3	20,00	€ 924,00
A16TA45804	0,80	0,87	1,69	4	22,00	€ 1.028,50
A16TA45805	1,00	0,90	1,90	5	24,00	€ 1.151,00

*The number of steps includes the platform

GUARDRAIL FOR 600x600 mm

GUARDRAIL FOR 800x800 mm

DESCRIPTION	CODE	PRICE	CODE	PRICES
FULL SIDE	A16TA60PACO	€ 174,50	A16TA80PACO	€ 210,00
SIDE RAILS EACH	A16TA60PALA	€ 73,00	A16TA80PALA	€ 87,50
SIDE + FRONT	A16TA60PAFL	€ 102,00	A16TA80PAFL	€ 123,00